

Models
covered

Side Entry
Mk2

Side Entry Mk2 Shower Cubicle

user and installation guide

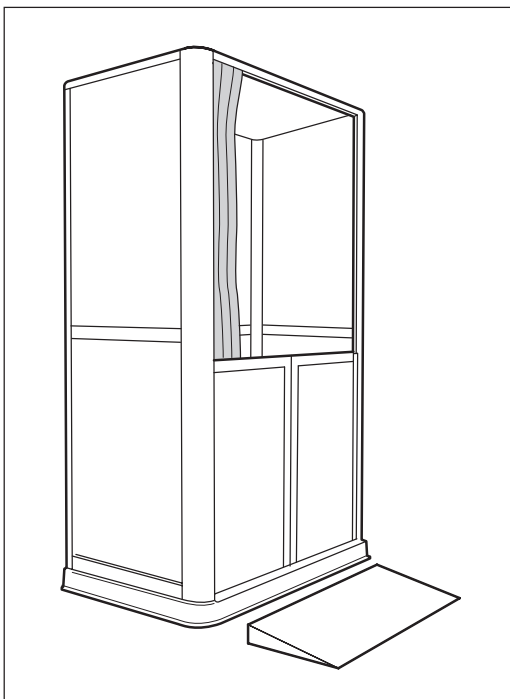

Side Entry Mk2 Shower Cubicle

Contents

Installation	2
Cleaning & Maintenance	14
Troubleshooting	15
Operation Guide	16
Accessories	17
Spare parts	18
Warranty	20

These products have been designed to the highest standards with safety, strength and quality in mind.

Follow the recommendations in this guide to ensure maximum benefit from your Chiltern Invadex Shower Cubicle.



Installation

General Guide

For your safety this installation should be completed by qualified personnel complying with all relevant regulations and byelaws.

Chiltern Invadex Shower cubicles are manufactured to many different specifications and sizes. It is therefore important that all services relevant to your model are complete and tested before you attempt to assemble your shower cubicle. All building work and decorating should be finished i.e. a suitable floor in place, skirting boards painted and fixed, walls and ceilings plastered and decorated.

Check all the items in the carton against the parts list on the enclosed leaflet.

Should you require any technical assistance or have any queries regarding installation procedures contact your nearest Chiltern Invadex Office. For an efficient response it will help if you have the model type and serial number to hand when you call (the serial number can be found on the label on the back panel).

Services - Incoming Water

The installation must be in accordance with local water company byelaws.

Mixer showers

Both hot and cold supplies must come from the water storage tanks with at least 2 metres head of water above the shower.

BOOSTER PUMP If the required head of water is not available a Twin Impeller Booster Pump can be employed. Do not use flow switches. All supplies should terminate close to the relevant controls with a 3/4" B. S. Male outlet. We strongly recommend that accessible isolating valves are fitted near to our units to facilitate future servicing, or isolation, in the event of an emergency.

Instantaneous Shower

15mm pipe with mains cold water supply.

Minimum operating pressure 1 bar (14.5 p.s.i.).

Permissible pressure variations 1 bar - 10 bar (14.5 p.s.i. - 145 p.s.i.).

Waste Water (fig 1)

The Chiltern Invadex Shower has a 12 volt pump positioned in the rear left hand corner of the cabinet. It pumps the waste water out of the base to a waste stack similar to that used by a washing machine.

The waste stack need only be in 1 1/4" (32mm) plastic but it is necessary to fit a trap to prevent odours.

The height of the waste stack should be between 508mm and 711mm above the floor level and fitted to the left hand rear of the proposed shower position (see diagram). This diagram is only one example of an installation. The position of the pipework will vary according to individual situations. NOTE: The lower the waste stack pipe the less water will be left in the trough once the pump is turned off.

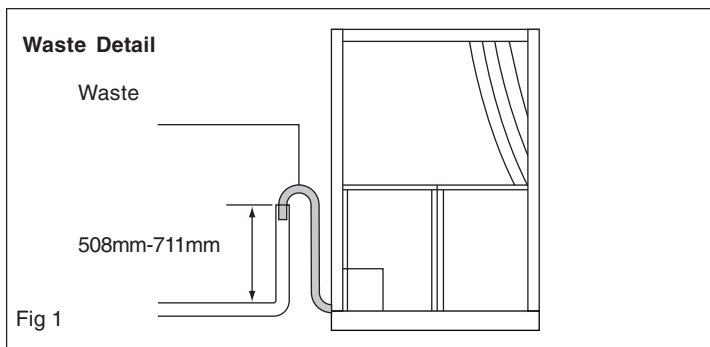

Fitting Instructions for Side Entry MK2 Shower Toilet

The 102mm (4") pipe in Chiltern Invadex Side Entry MK2 Shower Toilets is connected through the side panel. The toilet waste pipe must also be connected when the side panel is fitted.

The position of the pan on the base unit must relate to the individual requirements of the user and we recommend that this operation is left until later. Flush pipe and multikwik pan connector are supplied for standard installation. These can be extended on site. Additional parts are not included.

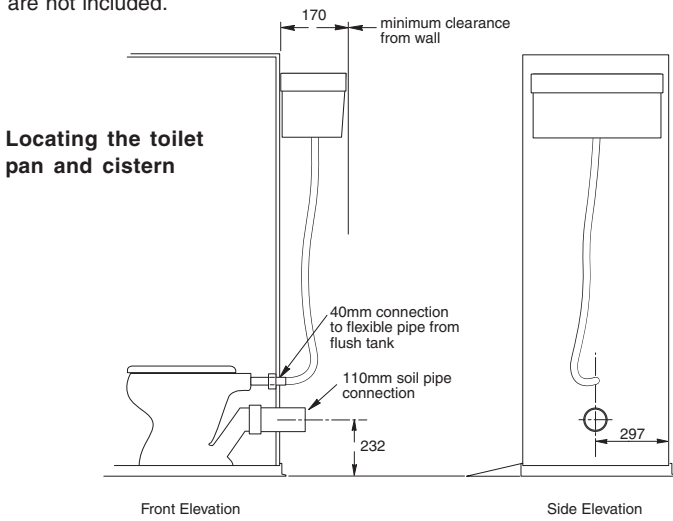

Installation (continued)

Wire Sizes

Incoming Mains-220-240V 50/60Hz (UK and Europe only) Cable size to suit application.

Electrical shower-(Please refer to manufacturers instructions - supplied separately)

Pumped waste-Cable supplied (do not replace cable if faulty. Please call your nearest Chiltern Invadex regional office for replacement)

Waste pump technical specification

operating voltage 12 volts DC (via transformer)

Current rating 3.0 amps maximum Rating- 315mA

Delivery output 18ltrs/min maximum

Class II

Insulation class-

Type B equipment-

All electrical installations should be carried out by qualified personnel, complying with all relevant byelaws and IEE regulations.

Prior to installing your shower cubicle find out whether the unit is to be installed with an electric shower unit, or thermostatic mixer unit. Then refer to the relevant figure for correct installation.

Bathroom IP Wiring Zones

Wiring block must be located outside of zones 0,1 and 2

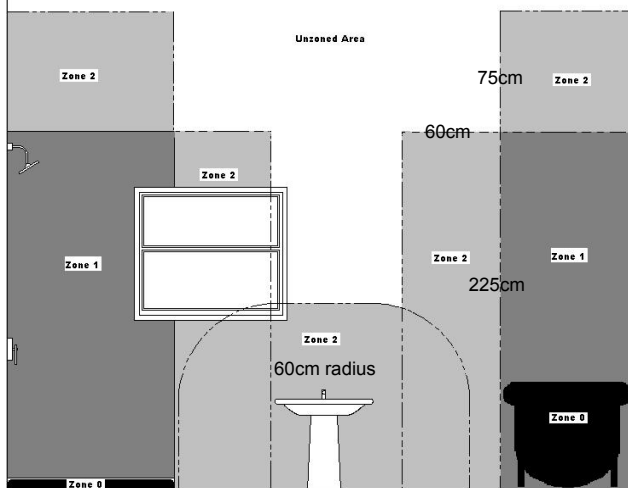

Electrical Installation

Shower & pumped waste

The correct wiring installation for the electric shower and pumped waste is shown in Fig 2. Please pay particular attention to the wire sizes.

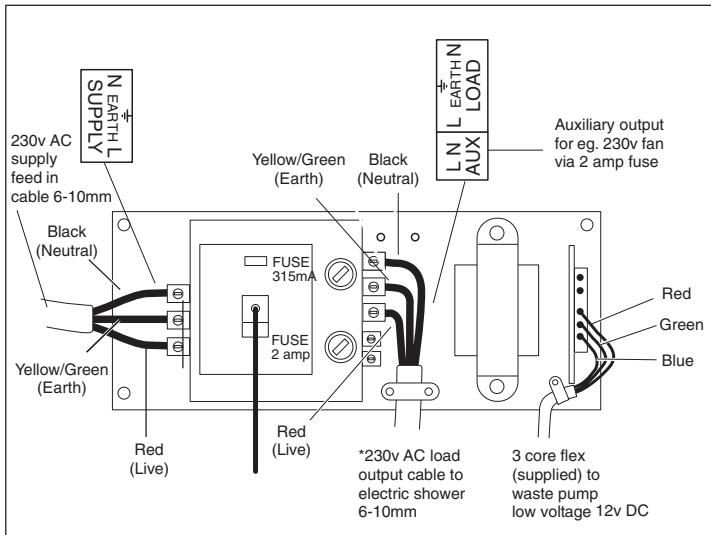

Fig 2

*Note: For mixer showers load output cable is not required.

Electrical supply

WARNING! GENERAL ADVICE FOR INSTALLERS

All installations must comply with I.E.E. regulations, Local Authority bylaws and electricity board regulations and must be carried out only by a qualified electrician.

Follow manufacturers instructions for installation of the shower heater unit for all electrical units.

SUGGESTED WIRING METHOD

Run a suitable cable (6-10mm sq for electric showers depending on power rating and supply distance) from the consumer box via 30mA RCD to the Double pole ceiling pull switch in the wiring block supplied. (This switch is used to isolate the shower as well as turning the shower waste pump on and off and must be accessible to a wheelchair user where applicable).

The wiring block is positioned at a maximum of 4m from the pump unit and complies with all mentioned regulations. Follow connection instructions included with wiring block to complete electrical supply.

Installation details (use fig 3 with instructions)

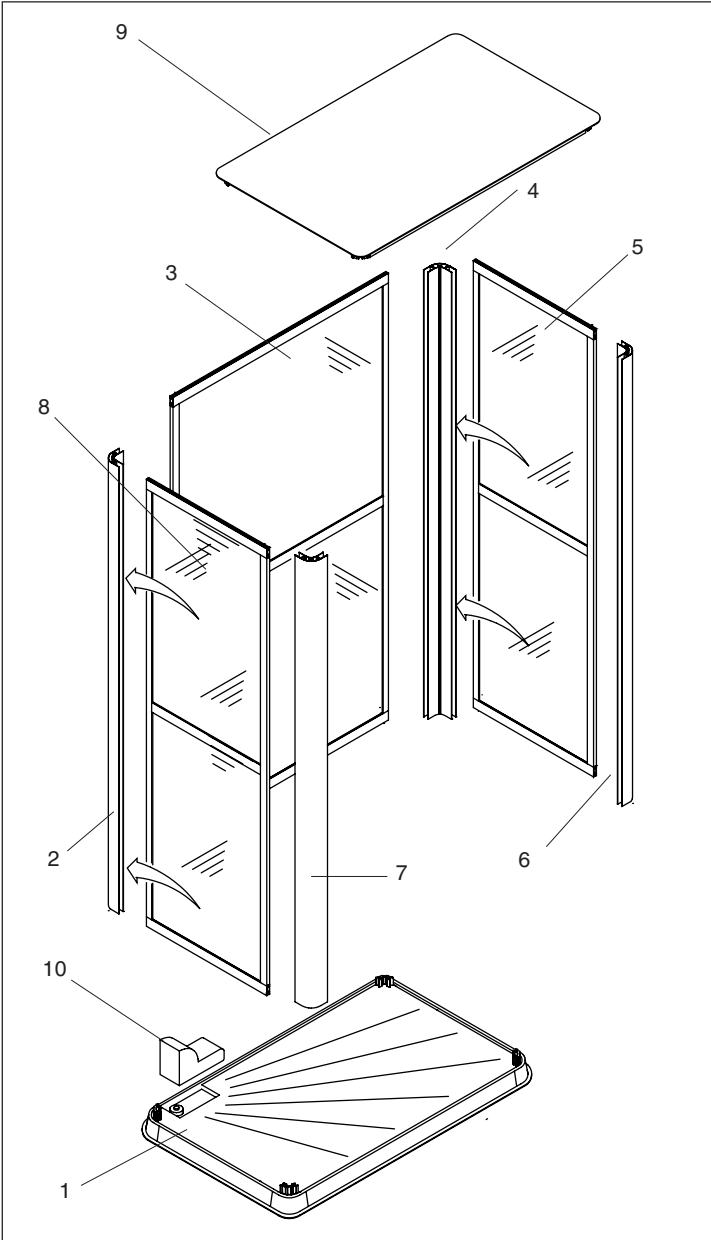

Fig 3

Note:

Assembling the cubicle in situ is usually easier than moving the assembled unit.

1. Fig 4.0-Ensure that the shower tray is placed on the floor and is level along its length and width. Also ensure that the 4x30mm blocks are inserted in the bottom of all 4 corner sections before assembly, as fig 4.1.

2. Fig 4.1-Locate the corner post onto the factory fitted foot section (the only corner post with a large hole in the bottom). Secure with the grub screw supplied (see inset). This is always on the pump post outlet.

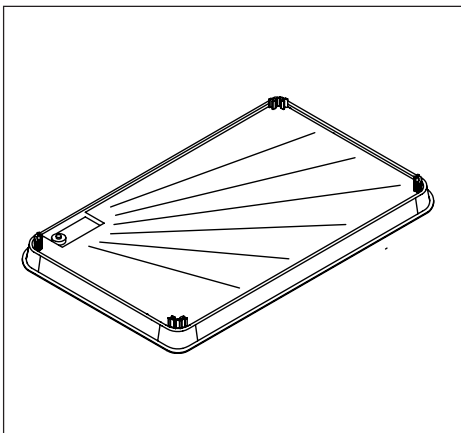

Fig 4

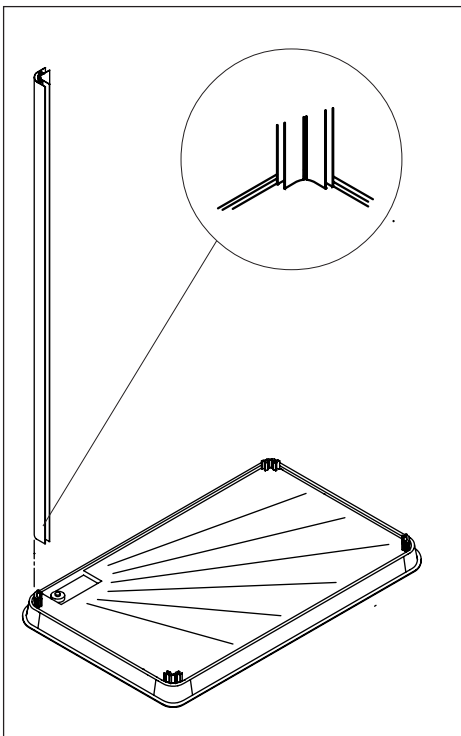

Fig 4.1

3. Fig 4.2 Locate the large rear back panel (3) into the channel in the corner post.

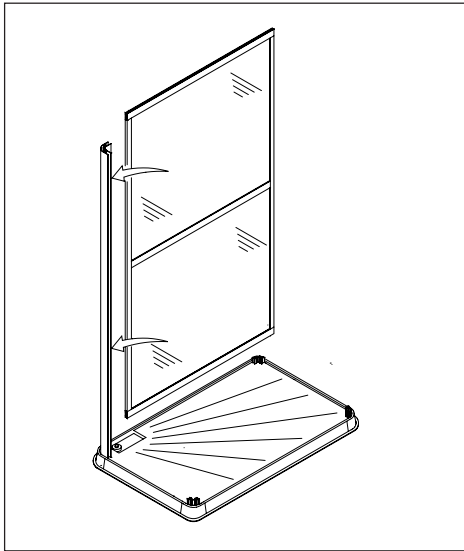

Fig 4.2

4. Fig 4.3 Slide in the second corner section. This section seat fixing plate (with 4 holdes) and is blank i.e without any door adjusting slots. Tighten the section with the allen key supplied.

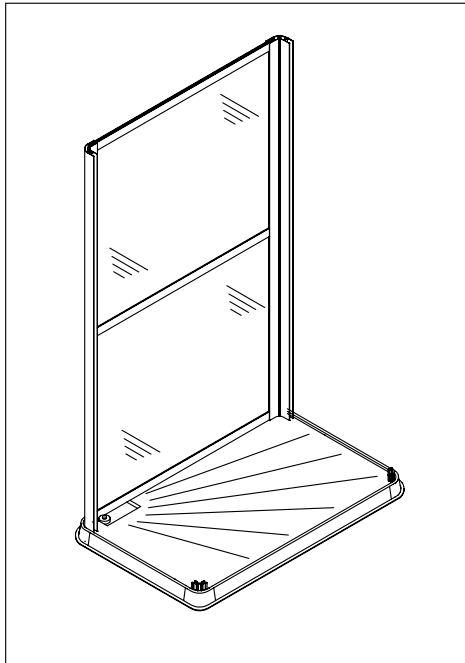

Fig 4.3

5. Fig 4.4 Locate the side panel (5) into the channel in the corner post.

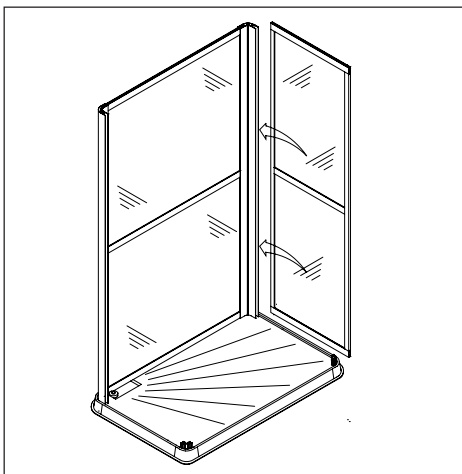

Fig 4.4

6. Fig 4.5 Position the corner post (6) repeat as instruction 4.

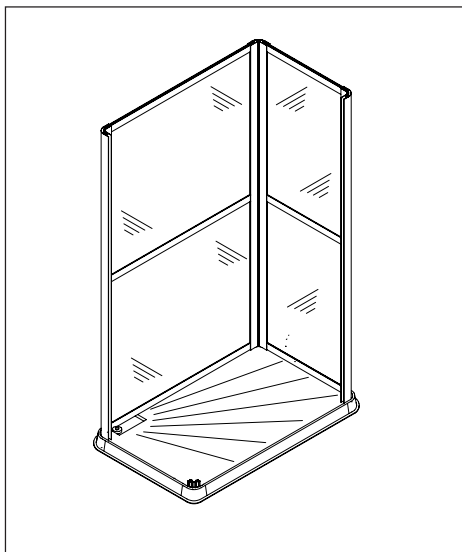

Fig 4.5

7. Fig 4.6 Locate the side panel (with the shower unit on it) (8) into the corner post channel (1) and locate corner post (7). Fix as previous.

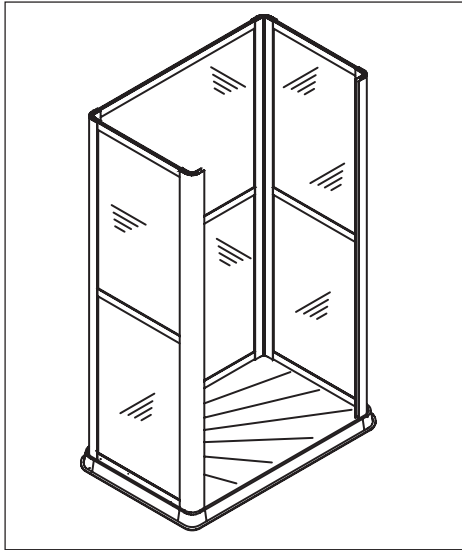

Fig 4.6

8. Fig 4.7 Position the grab rails onto the factory fitted securing blocks. Secure via 2 M4x6mm screws provided (see inset).

Key

- A - Back grab rail
- B - Side grab rail
- C - Shower riser rail

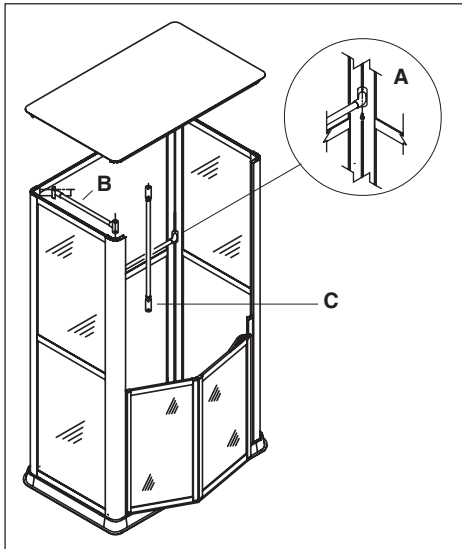

Fig 4.7

9. Fig 4.8. Prior to fitting the roof panel, ensure that the cubicle is square and upright.

Locate the roof panel (9) into the top of the corner posts one at a time.

Slackening the roof screws will be helpful if the roof is difficult to align. Secure with grub screws.

If an (optional) seat is to be fitted

The sliders must be positioned first. Feed them into the channel from the top and push them all the way down to the bottom of the side panel.

The seat can then be fitted using the screws provided.

Please contact your Chiltern Invadex regional office if a seat is required, but has not been ordered.

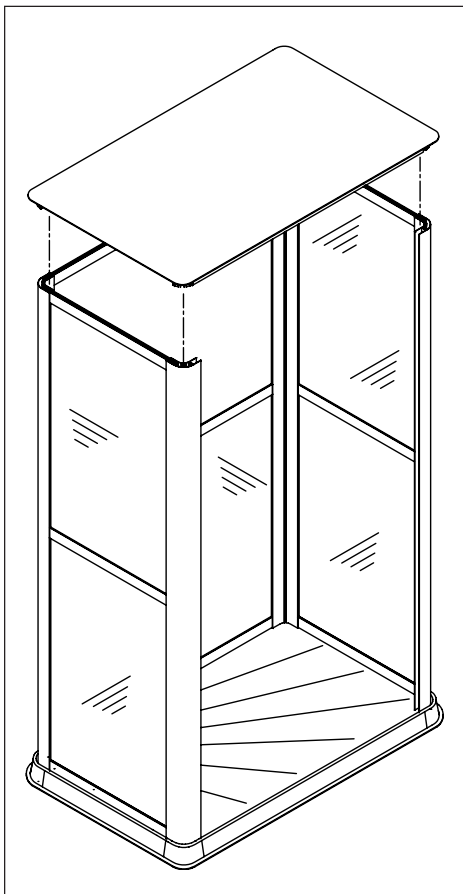

Fig 4.8

Door assembly - Swinging doors (standard)

10. Fig 4.9 Slide the doors into the corner posts (6,7), ensuring that the doors open outwards. Secure with the screws and slot covers provided (see Inset). Check that the doors open and close correctly and the bottom seal is in contact with the shower tray base. The door must nearly be touching when closed so as not to leak. Using the drill provided drill through the holes in the corner section and lock into position with the 1/2" self tapping screws and shakeproof washers provided.

Tri-fold/bi-fold doors

Slide the door into the corner section and tighten screws, shake-proof washers and slot covers loosely. Place the door receiver into the opposing corner section and tighten with two washers, slot covers and 1/2" screws. Before locking the door tight ensure that the door is straight and that the sliding handle locks correctly. Also, check that the magnetic strip mates with the one in the receiver.

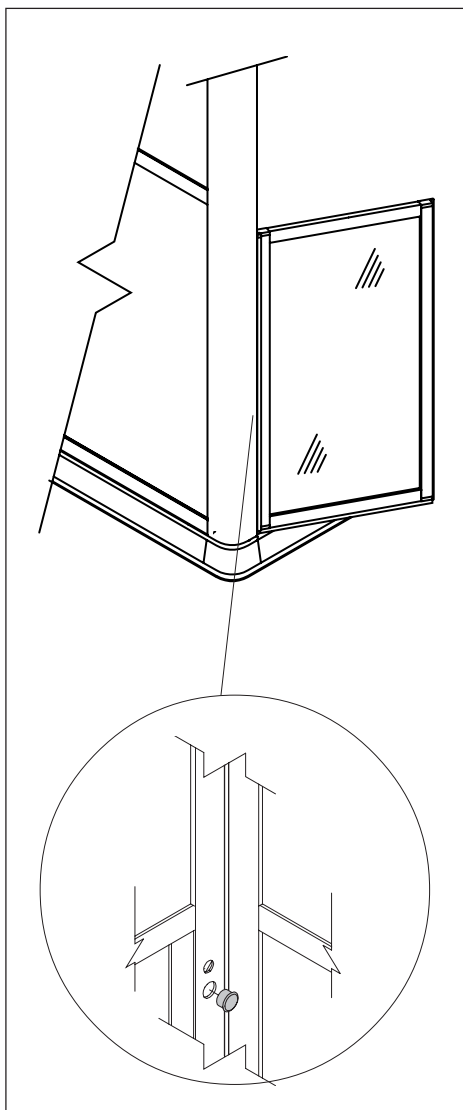

Fig 4.9

Pumped waste assembly

11. Fig 4.10 Push outlet (waste) hose through the hole in the corner post (1) and secure it to the stack pipe moulded in the base. Do not stretch the waste pipe, allow for possible adjustment. Connect the pump unit to the electrical connector, ensuring a firm fit. Push the motor housing into the base socket until the face of the pump and socket meet. Prior to fitting the pump cover (10) ensure that the electrical cable and waste pipe are clear of obstructions.

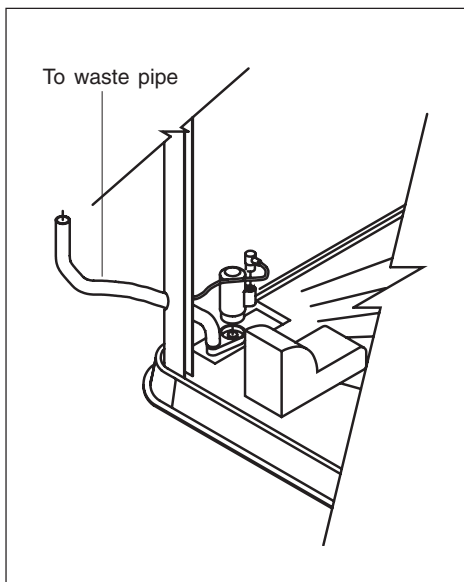

Fig 4.10

Cleaning & Maintenance

Regular

Shower Cubicles do not require any major maintenance, but you should follow these simple instructions:

Tray and Enclosure

To retain the surface quality of your shower cubicle, weekly cleaning using bathroom cleaning mousse or washing-up liquid, warm water and a soft cloth is recommended. For the slip resistant shower tray area you may need to use a stiff brush. Stubborn stains may require a non-scratch liquid cleaner.

Do not use oven cleaner or a scouring powder on any of the surfaces. Use of scourers will dull the finish of the surfaces and spoil the appearance of your tray and enclosure.

Shower Head (Handset)

If you live in a 'hard-water' area, the holes in the shower head will block more quickly. This will result in a poor spray and a reduction in the heating ability of some instant water heaters.

Remove rings from the shower head and vigorously scrape out the scale in the grooves, ensuring that the holes are clear.

Monthly

Pump Maintenance (for trays with pumped waste)

Regularly (monthly) lift pump from the socket in the base and remove foreign matter from the blades. Scrub the area around the pump with a long handled stiff brush. This will reduce the build up of scum and odours. Check that the small bore hole adjacent to the pump blades is clean. Replace pump cover making sure that the pump cover touches the shower base.

For performance regularly clean pump and shower head.

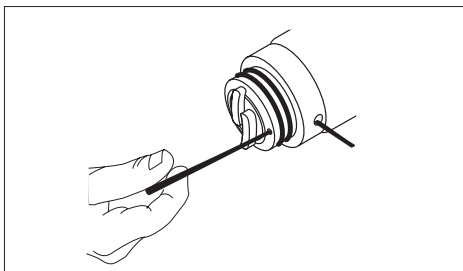

Annual

We recommend that the unit is serviced by a qualified Chiltern Invadex engineer. This will ensure that the unit complies with current health and safety regulations.

Troubleshooting

symptom	suggested cause	solution
Mixer Showers Reduced flow of water from the shower head.	Spray rings in the shower head have a build up of limescale and need cleaning.	Rub clean head of handset to clear any scale build up.
Electric Showers Reduced flow of water from the shower head. Temperature of showering water is too cool. Shower cuts out.	Water supply* pressure is lower than normal. Water supply is colder than normal, possibly due to weather conditons. Water supply* pressure is lower than normal. Temperature is set higher than safety cut-out. Spray rings in the shower head have a build up of lime-scale and need cleaning. Water supply* pressure is lower than normal.	See note 1 below. Check unit is on maximum heat setting/ reduce flow. Turn down the temperature and try again, Pump needs cleaning.
Pumped shower waste Water level higher than normal.	Waste hose is blocked. Water left in gully at back of shower after use.	Unblock waste hose. This is normal. The water left in the waste hose when the pump stops will run back when the pump stops.
Unpleasant odour from cubicle	Stagnant soapy water in the back gully.	The shower should be run for a couple of minutes after use to ensure that the residual water is clean.

Note 1: *Water supply pressures may be affected by simultaneous use of water at another point in the house, a fault in the house plumbing or a problem with the water supply to the house.

For further assistance please telephone your nearest Chiltern Invadex Regional Office. Remember that the service calls made after the expiry of the guarantee will be chargeable. If maintenance of the equipment is the responsibility of a third party, for example the Social Services, please contact them in the first instance.

Operation guide

If a seat is fitted

Fold down the seat, ensuring the feet are firmly placed on the shower tray, then transfer to the seat.

All cubicles

Pull the mains cord to provide power to the pump/shower.

Operate the shower noting the hot and cold position.

To minimise spray always ensure the shower curtain is closed.

Cross Infection

Warning: If this unit is to be utilised by many different bathers, then we would strongly recommend that this unit be cleaned with a medical disinfectant. Please contact your local infection control nurse for further advice.

Accessories

Folding Shower seat

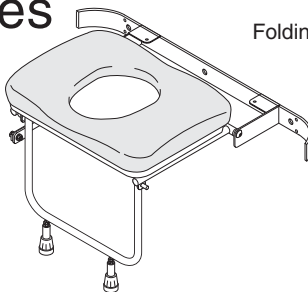

Vinyl seat

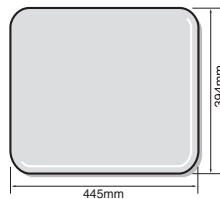

Flat padded

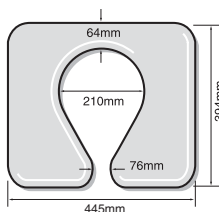

Large horseshoe

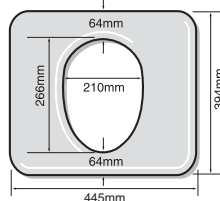

Large aperture

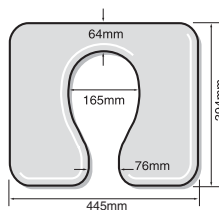

Medium horseshoe

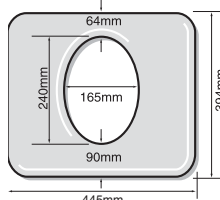

Medium aperture

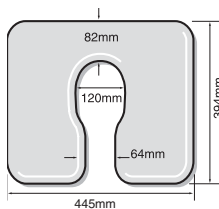

Small horseshoe

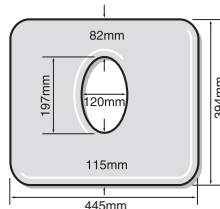

Small aperture

Spare parts

no	description	qty	part no
1	Shower Base (pumped waste)	1	IDISE03
2	Grab Rail - V/H (state panel and model)	1	SHSU023SE2
3	Back Panel	1	SHPA003SEMK2
4	Roof Light	1	SHSU042
5	Standard Door	1	SH00478SE2
6	Bifold Door*	1	SHPA009BSE2
7	Trifold Doors*	1	SHPA009(L)(R) SE2
8	Side panel *	1	SHPA001SE2
9	Roof	1	SHPA006SEMK2
10	Pump Cover	1	SH0646SE2
11	12v Waste Pump	1	SHPU030

*add L or R for left or right hand

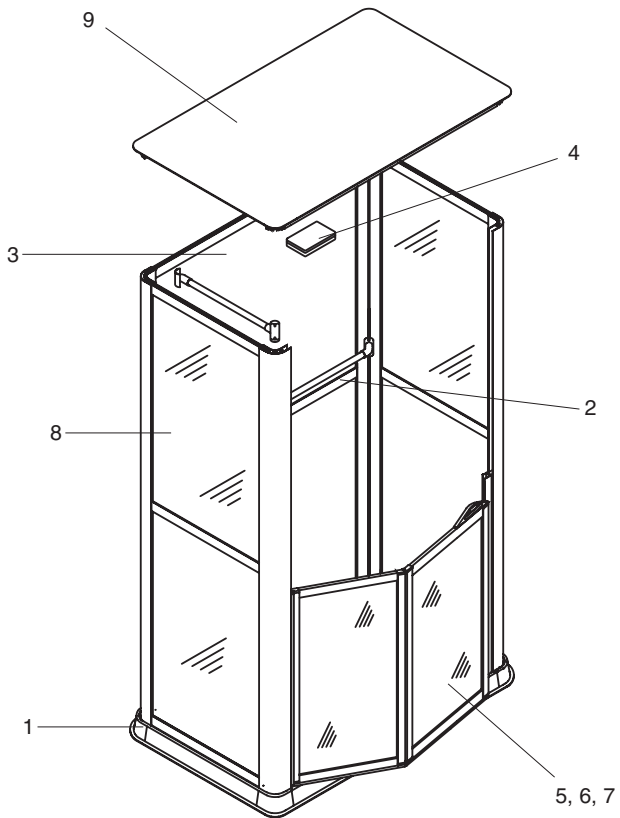

Waste pump Detail

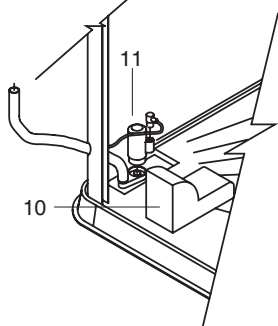

Warranty

Your Chiltern Invadex Shower Cubicle carries a 12 month warranty from the date of purchase (for guarantee on shower unit see manufacturers details), subject to the following:-

1. Should you experience any problems with our workmanship or materials within the first 12 months period, please contact your point of purchase.
2. Repairs made during the warranty period will be carried out free of charge, provided the product has been used strictly in accordance with the guidelines set out in this user guide.
3. Our warranty does not cover replacements, adjustments or repairs which may be required as result of normal wear and tear, wilful or accidental damage, misuse, neglect or any other cause which is beyond the control of Chiltern Invadex.
4. Modifications and repairs made to this product by unauthorised persons will render the warranty void.
5. Only parts manufactured or approved by Chiltern Invadex shall be used to repair this product. Use of unauthorised parts will invalidate all warranties and remove all liability from Chiltern Invadex for the safety of this product.
6. Chiltern Invadex shall in no event be liable for any damages, costs or expenses arising from any claim made under this warranty (save for any legal liability of Chiltern Invadex for death or personal injury resulting from the company's negligence in respect of its products).
7. Faults due to inadequate cleaning, limescale or other water impurities including debris not flushed from the supply pipe work prior to connection are excluded from this warranty.
8. This warranty does not affect your statutory consumer rights

Please fill in the information below for future reference

Dealers Name

.....

Address

.....

.....

..... Post Code.....

Telephone

Your Serial Number is

.....

Date of purchase

.....

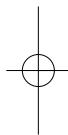
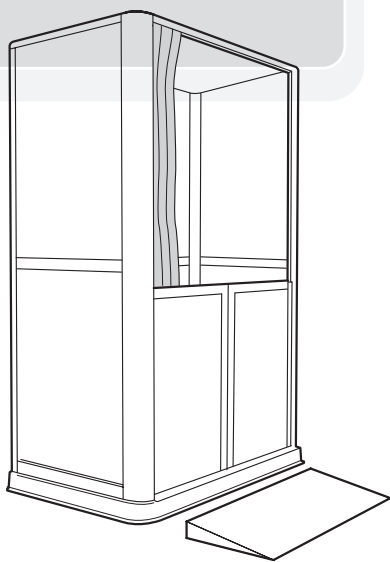

Side Entry Mk2 Shower Cubicle



Chiltern Invadex (UK) Ltd

126 Churchill Road
Bicester
Oxfordshire
OX26 4XD

Tel: 01869 365500
Fax: 01869 365588

Web: www.chilterninvadex.co.uk
E-mail: sales@chilterninvadex.co.uk



The crossed wheeled bin symbol shown on the pumped waste option of this product indicates that the item must not be disposed of with general household waste. Proper recovery of your waste electronic and electrical equipment will ensure safety of human health and the environment.

For more information where the product can be safely disposed of please contact your Local Authority, the dealer from where the product was purchased or Chiltern Invadex (UK) Limited.