

# SHOWER WASTE PUMP

# P2

See p36-38  
for Tray options



Kit illustrated

## Shower waste pump kit

- Where access to drainage is difficult a shower waste pump allows waste water to be pumped away, without the need to rely on a gravity fall
- Suits all Chiltern Invadex shower trays (except Cardale which comes with its own pump) as shown below
- Quiet and filterless low voltage pump (12v)
- Simple to install and maintain
- Audible alarm to indicate blockages
- Pump lid snaps on and is easily removed for routine cleaning and maintenance

## Shower waste pump kit compatibility selector



Shown recessed



Shown surface mounted

	TRAY DESCRIPTION	TYPICAL TIMBER FLOOR CONSTRUCTION	TYPICAL CONCRETE/SCREED FLOOR CONSTRUCTION
LEVEL ACCESS	Sandwell MK3 655	✓	×
	Sandwell MK3 760	✓	×
	Westdale 655	✓	×
	Westdale 760	✓	×
	Westdale 850	✓	×
	Westdale 1000	✓	×
	Cardale MK2	Supplied with integral pump	Supplied with integral pump
EASY ACCESS	Abbeydale 760	✓	×
	Abbeydale 850	✓	×
	Abbeydale 950	✓	×
	Abbeydale 1050	✓	×
	Dovedale MK2	✓	✓
	Edale MK2	✓	✓
STEP-IN	Berriedale	✓	✓
	Ferndale	✓	✓

code	product	Price
115-00001	Standard Pump Kit, single unit	<b>£395</b>
115-00001	Standard Pump Kit, box of 5 units	each <b>£390</b>
115-00001	Standard Pump Kit, box of 10+ units	each <b>£385</b>

Package includes wiring block - which controls the pump manually, pump and necessary fittings & connections to the above floor outlet or Invawaste - see pages 39-40.

## Technical Information

Notes: Flexi-pipe supplied (40mm) for flow into box. Flow outlet from box is 22mm

Maximum 15 litres/min drainage (dependent on type of shower tray)

Case constructed from white flame retardant ABS

### Side and end elevation

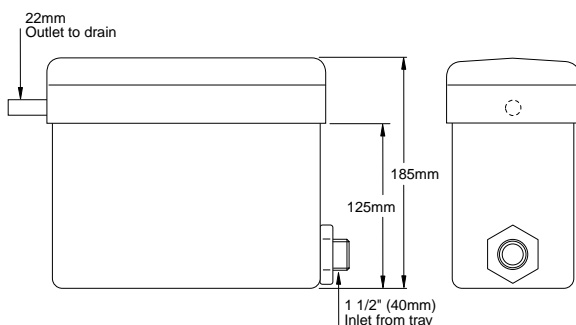

### Plan elevation

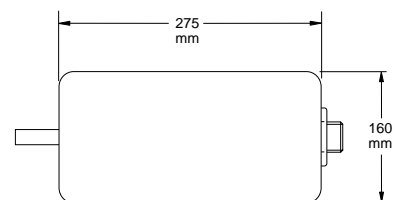

### SYMBOLS:

Bulk/oversized item



Made to order (see P200)



Tel: 0800 917 0399

www.chilterninvadex.co.uk

Fax: +44 (0) 1869 365588

sales@chilterninvadex.co.uk

# SHOWER WASTE PUMP

# P2

See p36-38  
for Tray options

## Technical Information

For further technical information go to the Shower trays & enclosure specification guide. This section starts on page 52.

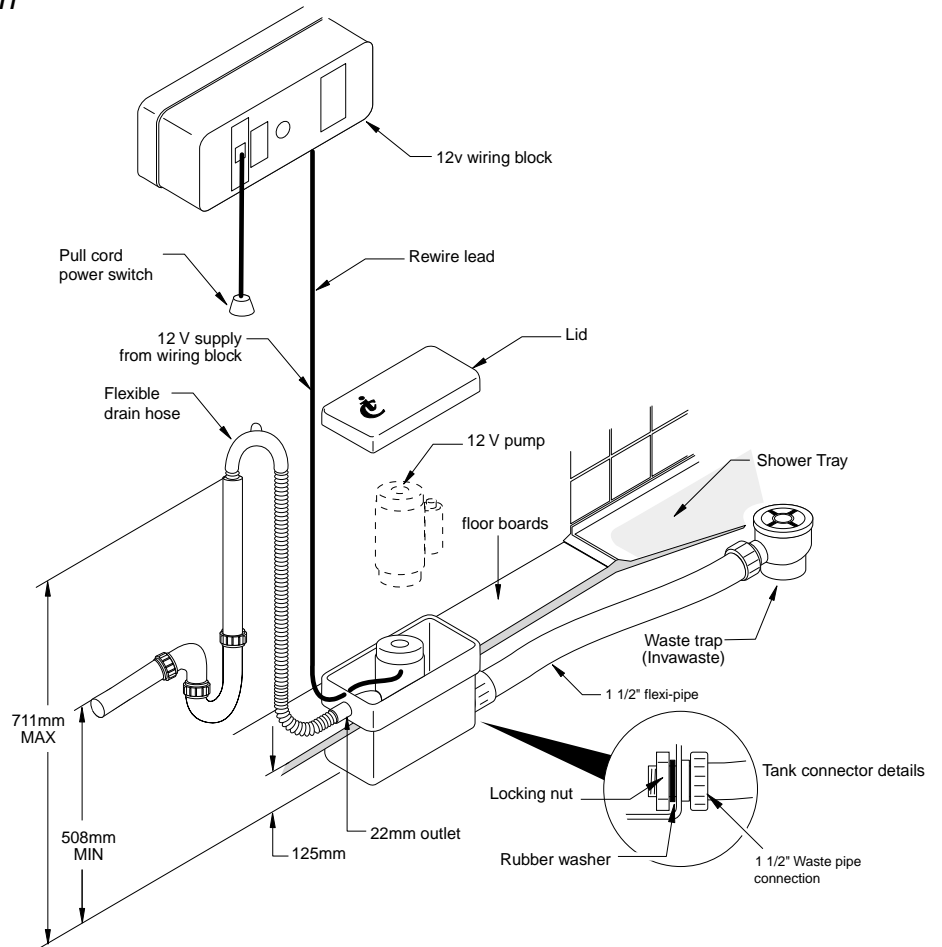

**Notes:**

Typical stack detail, waste hose running into standpipe with P-trap. Waste pipe laid is suitable gradient before running into hopper head, gully or SVP.

**Please note:**

Chiltern Invadex can supply an automatic version of the Shower Waste Pump kit shown above. Please contact the Technical Helpdesk for assistance.

Typical installation utilising washing machine type waste

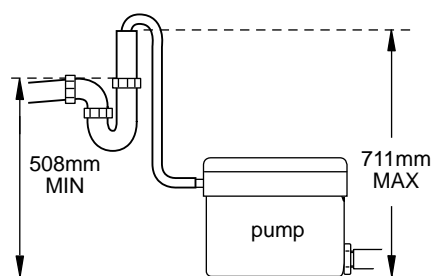

Maximum height from base of box to top of standpipe 711mm (28") down to a minimum height of waste discharge 508mm (20") will give maximum efficiency of the pump, with a suitable down gradient slope.

**SYMBOLS:**

Bulk/oversized item



Made to order (see P200)



Tel: 0800 917 0399

www.chilterninvadex.co.uk

Fax: +44 (0) 1869 365588

sales@chilterninvadex.co.uk